

LoRaWAN ambient air monitor

(CO₂, temperature, humidity, barometric pressure)



Features

- State-of-the-art non-dispersive infrared (NDIR) technology to measure CO₂.
- Integrated industry standard humidity and temperature sensor.
- Integrated high accuracy barometric pressure sensor.
- Place and measure: no setup required; just switch it on.
- Unattended real-time monitoring for several years without replacing batteries.
- Compatible with LoRaWAN™ networks of any provider.
- Robust polycarbonate enclosure: weatherproof, impact-, UV-resistant.
- Standard alkaline (C-type) batteries: available everywhere.
- CE compliant, Radio Equipment Directive (RED) 2014/53/EU.

Applications

- General indoor and outdoor air quality monitoring.
- Global environmental surveillance: ground and atmospheric CO₂ sensing.
- Ventilation control: for good indoor air quality and energy savings.
- Process yield and economic efficiency: e.g. in greenhouses, mushroom farming, food packaging, transportation/storage, chicken hatcheries and incubators.
- Personal safety: in confined spaces where combustion is present or gas leakage could occur such as garages, tunnels, public bars, restaurants or burners.
- Automotive: refrigerant leakage control and HVAC fresh air supply demand sensing.



decentLab

Decentlab GmbH

Ueberlandstrasse 129 – 8600 Duebendorf – Switzerland

Tel. +41 44 809 3595 – mail@decentlab.com – www.decentlab.com

Description

Decentlab's ambient air monitor continuously measures carbon dioxide (CO₂) concentration, temperature, humidity and barometric pressure. Barometric pressure and temperature data are used by the CO₂ sensor to compensate for temperature and pressure variations and the elevation above sea level. Sensor data are transmitted in real-time using LoRaWAN™ radio technology. LoRaWAN™ enables encrypted radio transmissions over long distances while consuming very little power. The user can obtain sensor data through Decentlab's data storage and visualization system, or through the user's own infrastructure. Visit <http://www.decentlab.com/> for more information about Decentlab's data cloud service.

Automatic sensor calibration

The device periodically performs an automatic calibration routine for the CO₂ sensor. The calibration routine requires no interaction by the user. The calibration period is set to 8 days by default. Every 8 days, the device evaluates all sensor data of the last 8 days and performs a recalibration. The recalibration is based on the assumption that the sensor has been exposed to fresh air (which is assumed to contain 400 ppm CO₂) for at least a few minutes during this period. If the device is operated indoors, it is enough to ventilate the room with fresh air once in a while.

The user can configure the calibration period for example by the following user interface commands:

- `set param 2 192` (set calibration period to 192 hours = 8 days: recommended default)
- `set param 2 0` (disable calibration function)

Please refer to section “Device configuration” for a description of the user interfaces.

Device specifications

Device logging function

Sampling interval	1 min (default value)
Data upload interval	10 min (default value)
Reported sensor data (average of 10 measurements)	CO2 concentration (filtered / unfiltered) CO2 sensor raw values (filtered / unfiltered) CO2 sensor temperature CO2 sensor status information Air humidity and temperature Barometric pressure and temperature Battery voltage

Integrated CO₂ sensor specifications (as specified by sensor manufacturer)

Operating principle	Non-dispersive infrared (NDIR)
Measurement range	0 to 2000 ppm (extended range up to 10000 ppm)
Accuracy	±50 ppm or ±3 % of reading ¹ (extended range ±10 %) ²
RMS noise	25 ppm @ 1000 ppm

Integrated humidity / temperature sensor (as specified by sensor manufacturer)

Operating principle	Digital CMOSens® technology
Measurement range	0 – 100 % RH, –40 to +125 °C
Accuracy (typical)	±2 % RH, ±0.3 °C

Integrated barometric pressure sensor (as specified by sensor manufacturer)

Operating principle	Piezo-resistive absolute pressure sensor
Operation range	300 – 1100 hPa, –40 to +85 °C
Accuracy (typical)	±1 hPa

Radio / wireless

Wireless technology	LoRaWAN™
Wireless security	AES-128 data encryption
LoRaWAN device type	Class A end-device
Supported LoRaWAN features	OTAA, ABP, ADR, adaptive channel setup
Wireless range	> 10 km (line of sight), approx. 2 km (suburban) ³
RF transmit power	14 dBm (25 mW)
Effective radiated power	11.9 dBm ⁴

1 Condition: 10 – 40 °C, 20 – 60 % RH

2 Extended range accuracy is not calibrated or guaranteed, it is extrapolated from calibrated range (0 to 2000 ppm)

3 Decentlab reports successful transmissions over 56 km distance

Receiver sensitivity	-146 dBm ⁵
Frequency bands	868 MHz (EU version), 915 MHz (US version) ⁶
Antenna	Integrated omnidirectional antenna featuring a near-perfect radiation pattern ⁴

Power supply

Internal battery type	2 × alkaline C batteries (R14)			
Power consumption (average)	≤ 0.9 mW			
Battery lifetime estimation ⁷	Sampling period	Send period	SF	Lifetime
	1 min ⁸	10 min ⁸	SF7	5.1 years
	1 min ⁸	10 min ⁸	SF12	2.4 years
	10 min	10 min	SF7	9.9 years
	10 min	10 min	SF12	2.9 years
	6 min	60 min	SF7	12.5 years
	6 min	60 min	SF12	8.7 years

Operating conditions

Temperature	-10 to 50 °C
Humidity	0 – 95 % RH (non-condensing)

Mechanical specifications

Dimensions	122 × 81 × 67 mm
Weight	376 g including batteries (246 g without batteries)
Enclosure	Polycarbonate (weatherproof, impact-, UV-resistant). Air inlet on the bottom: protected by shroud and a fine-meshed stainless grid.

4 See Appendix A: Antenna performance measurement

5 Specified by radio chip vendor

6 Contact us for region specific options

7 Including alkaline battery self-discharge of 3.6 % per year (conservative estimation); battery capacity: 20000 mWh.

8 Default value

Operating instructions

The product usually requires no user interaction. If you open the enclosure, e.g. in order to replace the batteries, unscrew the four plastic screws and carefully open the lid.

CAUTION: Make sure the sensor unit does not drop out of the enclosure while opening! Do not touch the electronic components and sensors! Particularly the CO₂ sensor is very sensitive to mechanical stress.

NOTE: When closing the lid, make sure the lid is fitted the right way, so that the enclosure is properly sealed: A little nose in the enclosure fits a notch in the lid and vice versa.

Replacing batteries

Insert 2 high-quality alkaline C batteries (R14) into the battery holder on top of the sensor unit. The device operates until the battery voltage drops to 2.0 V. Always replace both battery cells with two identical fresh batteries.

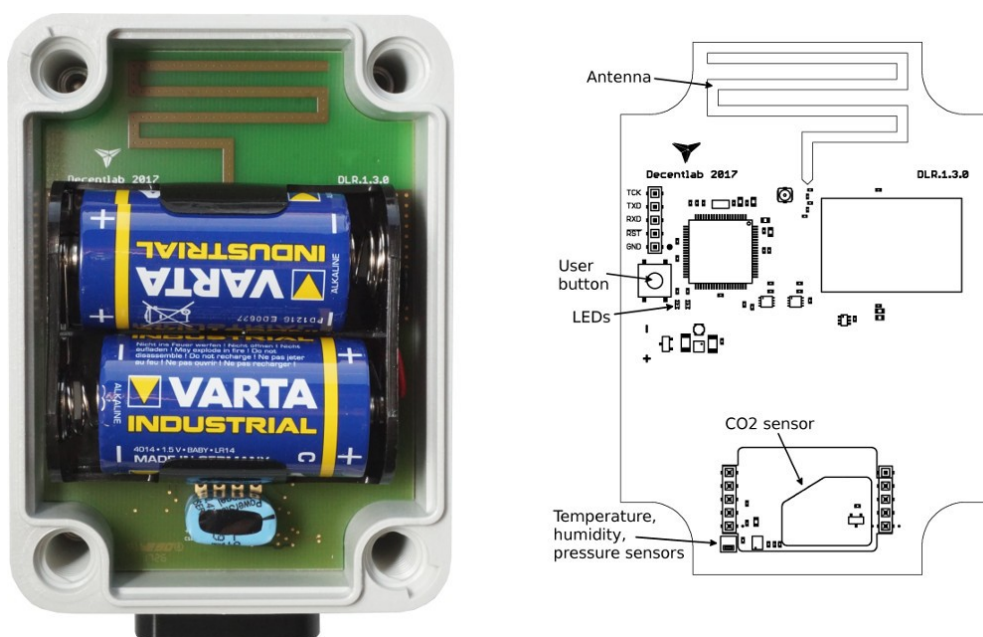

Illustration 1: Sensor unit inside enclosure with batteries inserted (left); component side of the sensor unit (right).

Operating modes

The device has three operating modes:

- **Reset:** System (re-)start; both LEDs light up for a short time.
- **Active mode:** Periodic measurements and data transmissions; green LED flashes for each measurement.
- **Test mode:** Measurements and data transmissions at fastest possible rates; blue LED is on. **NOTE:** Use only momentarily, e.g. for testing the wireless connection. The device will switch automatically to active mode after 20 min.
- **Sleep mode:** No measurements and data transmissions (power save mode, for shelf storage).

Switching between operating modes

The user button allows to switch between the operating modes as shown in Illustration 2. To perform a device reset, switch to sleep mode first (if necessary) by pushing the button for 3 seconds (until LEDs flash three times); wait 3 seconds; then push the button for 3 seconds (until LEDs light up). To switch between active and test mode, push the button for 1 second (blue LED on / off). If the blue LED is off, the device is in active or sleep mode. If the blue LED is on, the device is in test mode. To check whether the device is active or in sleep mode, push the button twice for 1 second; if the blue LED goes on and off, the device is in active mode; otherwise, the device is in sleep mode.

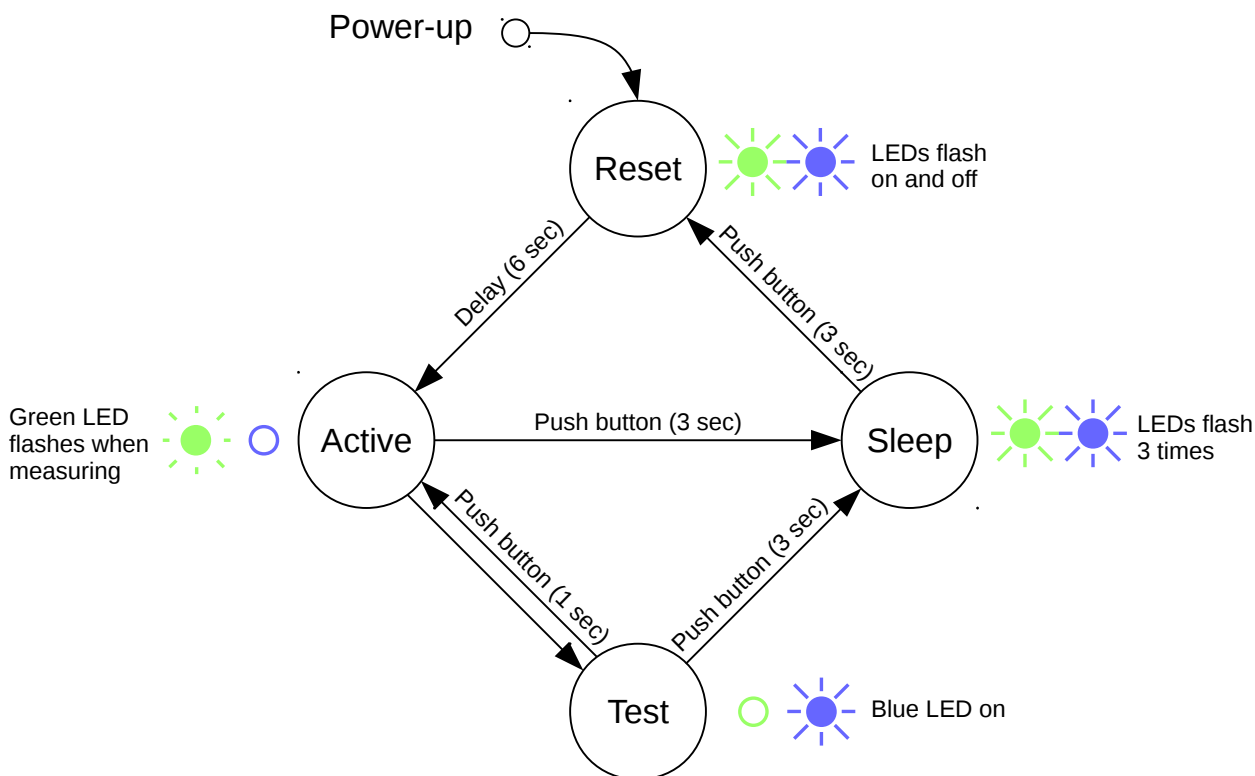

Illustration 2: Device operating mode state diagram.

Measurement cycle (active mode)

During the active mode, the device periodically reads the sensors with sampling period T_s . When the send period $T_{TX} = n \cdot T_s$ has expired, the device computes the average of the collected sensor values (at most 10 values). After a random delay of 0...8 seconds, the device transmits the aggregated sensor data. If the device has not yet joined the LoRaWAN network, it will try to join until it succeeds (maximum 3 attempts per sampling period). Afterwards, it will transmit the data (TX data). Following the data transmission, two receive slots are opened (RX1 and RX2). During these time slots, the device is ready to receive data from the network (downlink messages) as defined in the LoRaWAN™ specification.

As shown in the diagrams, the device is idle most of the time. During the idle time, the current consumption is extremely low.

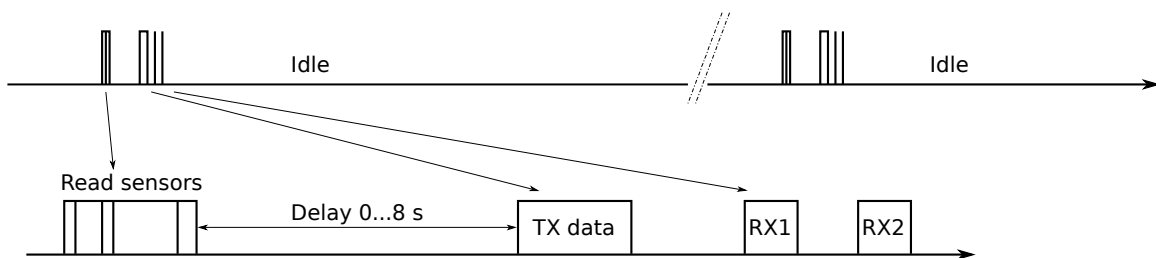

Illustration 3: Device activity during the active mode.

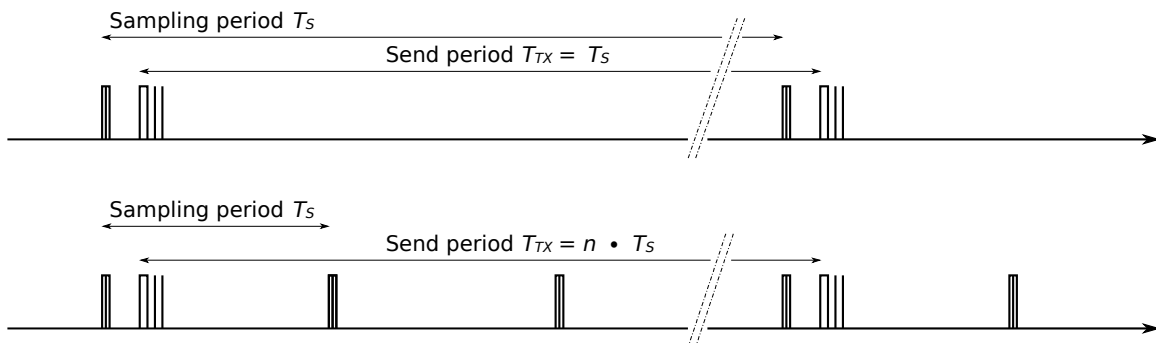

Illustration 4: Sampling period vs. send period shown for two configurations. Default for DL-LP8P: $T_s = 1 \text{ min}$, $T_{TX} = 10 \cdot 1 \text{ min}$ (second row).

LED signaling (active mode)

- Read sensors: green LED flashes once.
- Data sent successfully: green LED flashes 2 times.
- Data could not be sent: green LED flashes 4 times.

Device configuration

The user can configure a rich set of device parameters, such as sampling interval, LoRaWAN data rate, ADR settings and many more. If desired, the parameter settings can be stored permanently in the internal non-volatile memory. The user can configure the device via two interfaces:

- Command line interface: via a serial cable (UART – USB) connected to a computer.
- Downlink command interface: over the air using LoRaWAN downlink messages.

For a full description of the command line interface and the downlink command interface, please find the specific documents on <https://www.decentlab.com/support>.

Mounting instructions

Mount the device in upright position, the air inlet facing downward. Prefer a mounting location which is protected against rain and direct sun radiation in order to achieve best sensor data quality.

For best radio performance, position the device in such a way that the device lid faces roughly in the direction of the next gateway. Avoid metallic objects close to the device.

The housing includes 4 threaded bushes (M4) in a 90 × 60 mm rectangle (see Illustration 5). This enables easy installation using standard M4 bolts.

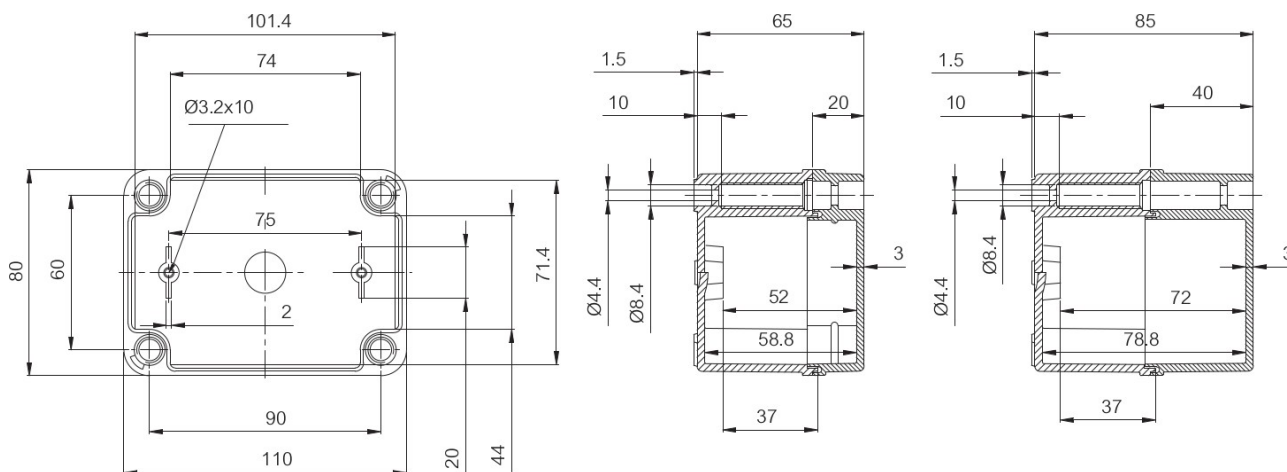

Illustration 5: Housing dimensions. Note: Drawing not including air inlet. Dimensions in mm.

Ordering information

Device model references

DL-LP8P-EU868	EU version
DL-LP8P-US915	US version
	Other options: contact us

Sensor data message format

Message:	Header	Sensor 0 data (optional)	Sensor 1 data (opt.)	...	Sensor 15 data (opt.)
-----------------	--------	--------------------------	----------------------	-----	-----------------------

- Message length is variable, depending on which sensor data are included. Minimum length is 5 bytes (header only). Maximum length is 5 bytes + all sensor data (see below).
- Integers are big endian: MSB first byte, LSB last byte.

Header:	Version	Device ID	Flags
----------------	---------	-----------	-------

- Version: 1 byte; version = 2 for current protocol version.
- Device ID: 2 bytes; 0...65535.
- Flags: 16 bits: flag 15 | flag 14 | ... | flag 0 (LSB).
- The flags indicate, if data of the respective sensors are included in the message or not:
Flag n == 1: sensor n data included; flag n == 0: not included.

Details

Field	Parameter name	Type	Conversion	Unit
Header	Version	uint8		
Header	Device ID	uint16		
Header	Flags	uint16		
Sensor 0	Air temperature	uint16	$x / 65536 \cdot 175.72 - 46.85$	°C
Sensor 0	Air humidity	uint16	$x / 65536 \cdot 125 - 6$	%
Sensor 1	Barometer temperature	uint16	$(x - 5000) / 100$	°C
Sensor 1	Barometric pressure	uint16	$x \cdot 2$	Pa
Sensor 2	CO ₂ concentration	uint16	$x - 32768$	ppm
Sensor 2	CO ₂ concentration (low-pass filtered)	uint16	$x - 32768$	ppm
Sensor 2	CO ₂ sensor temperature	uint16	$(x - 32768) / 100$	°C
Sensor 2	Capacitor voltage 1	uint16	$x / 1000$	V
Sensor 2	Capacitor voltage 2	uint16	$x / 1000$	V
Sensor 2	CO ₂ sensor status	uint16	x	
Sensor 2	Raw IR reading	uint16	x	
Sensor 2	Raw IR reading (low-pass filtered)	uint16	x	
Sensor 3	Battery voltage	uint16	$x / 1000$	V

Example 1 (all sensor data included)

Message (hex):

020578000f67bd618d1cedbd1081d981f4895b0bd80bb50000959895390c25

02	Version	=		2
0578	Device ID	=		1400
000f	Flags	=	0b00000000000001111	
67bd	Air temperature	=		24.36 deg
618d	Air humidity	=		41.63 %
1ced	Barometer temperature	=		24.05 deg
bd10	Barometric pressure	=		96800 Pa
81d9	CO2 concentration	=		473 ppm
81f4	CO2 concentration (LPF)	=		500 ppm
895b	CO2 sensor temperature	=		23.95 deg
0bd8	Capacitor voltage 1	=		3.032 V
0bb5	Capacitor voltage 2	=		2.997 V
0000	CO2 sensor status	=		0
9598	Raw IR reading	=		38296
9539	Raw IR reading (LPF)	=		38201
0c25	Battery voltage	=		3.109 V

Example 2 (CO₂ sensor data not included)

Message (hex):

020578000b67bd618d1cedbd100c25

02	Version	=		2
0578	Device ID	=		1400
000b	Flags	=	0b00000000000001011	
67bd	Air temperature	=		24.36 deg
618d	Air humidity	=		41.63 %
1ced	Barometer temperature	=		24.05 deg
bd10	Barometric pressure	=		96800 Pa
----	CO2 concentration	=		----
----	CO2 concentration (LPF)	=		----
----	CO2 sensor temperature	=		----
----	Capacitor voltage 1	=		----
----	Capacitor voltage 2	=		----
----	CO2 sensor status	=		----
----	Raw IR reading	=		----
----	Raw IR reading (LPF)	=		----
0c25	Battery voltage	=		3.109 V

Example 3 (only battery voltage)

Message (hex):

02057800080c25

02	Version	=		2
0578	Device ID	=		1400
0008	Flags	=	0b000000000000001000	
----	Air temperature	=		---- deg
----	Air humidity	=		---- %
----	Barometer temperature	=		---- deg
----	Barometric pressure	=		---- Pa
----	CO2 concentration	=		---- ppm
----	CO2 concentration (LPF)	=		---- ppm
----	CO2 sensor temperature	=		---- deg
----	Capacitor voltage 1	=		---- V
----	Capacitor voltage 2	=		---- V
----	CO2 sensor status	=		----
----	Raw IR reading	=		----
----	Raw IR reading (LPF)	=		----
0c25	Battery voltage	=		3.109 V

Declaration of conformity

We,

Decentlab GmbH
Ueberlandstrasse 129
8600 Duebendorf
Switzerland,



declare under our own responsibility that the product

Reference	Name
DL-LP8P-EU868	LoRaWAN ambient air monitor

to which this declaration refers conforms with the relevant standards or other standards documents

- EN 300 220-1 V3.1.1: 2017-02
- EN 300 220-2 V3.1.1: 2017-02
- EN 301 489-1 V2.2.0: 2017-03
- EN 301 489-3 V2.1.1: 2017-03

According to

- Radio Equipment Directive (RED) 2014/53/EU
- Electromagnetic Compatibility (EMC) Directive 2014/30/EU

Duebendorf, 27. July 2018

Reinhard Bischoff, Managing Director

A handwritten signature in black ink, appearing to read 'R. Bischoff', written in a cursive style.

Appendix A: Antenna performance measurement

No : DE.17.039.F01

Page 21 / 24

Measurement Results:

EUT	DLR1-LP8		
Test performed	Effective radiated power (ERP)		
Verdict, Test	Pass		
Modification	None		
Mode of operation	Transmitter mode		
Test date, time	13.06.2018 09:37:06		
Antenna height	1.30 m	Antenna polarization	Vertical
EUT position	0 to 360 Degree	Antenna distance	3 m
Measurement settings	Radimtion Version: 2017.1.6, RBW: 1 kHz, VBW: 300 kHz, Sweep time: Auto [120 ms], Step freq: Linear: 250 Hz steps, Attenuator: Auto [10 dB], Internal preamp: 20 dB, Measure time: 10 ms, Measurement equipment: TP_RE_30M-1G_ETSI_Ver		

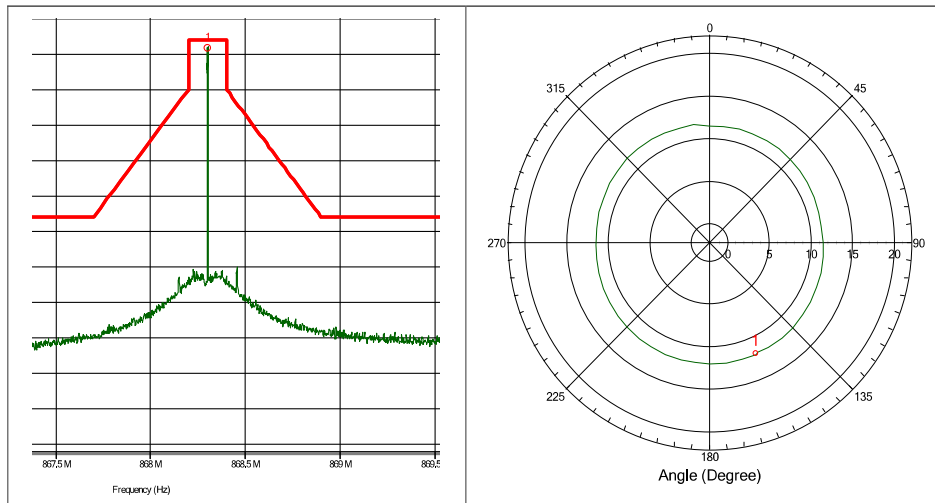

Detected peaks

Peak Number	Frequency	Peak	Peak Difference	Status	Angle	Height	Polarization
1	868.302 MHz	11.9 dBm	-2.14 dB	Pass	157 Degree	1.3 m	Vertical

Limits:

ETSI EN 300 220-2, Table C.1 OFB: 863 MHz to 870 MHz <= 0.1% duty cycle or polite spectrum access	25 mW e.r.p (14 dBm)
---	------------------------------------

EMV Prüfstelle Zürich – Technopark – 8005 Zurich