

LoRaWAN High-Precision Pressure / Depth and Temperature Sensor

High-precision piezoresistive pressure measurement



Features

- LoRaWAN™-enabled high-precision piezoresistive pressure sensor / depth gauge including temperature sensor.
- Pressure measurement relative to atmospheric pressure (absolute pressure on request).
- Range: 0 to 1 bar (0 to 10 m); up to 30 bar (300 m) on request.
- Cable length: 10 m (other lengths on request).
- RS-485 interface for robust operation in harsh environments even with cable lengths of several hundred meters.
- Place and measure: no setup required.
- Configurable via command line interface and downlink command interface.
- Unattended real-time monitoring for several years without replacing batteries.
- Robust polycarbonate enclosure: weatherproof, impact-, UV-resistant (IP67).
- Standard alkaline batteries: available everywhere.
- CE compliant, Radio Equipment Directive (RED) 2014/53/EU.

Applications

- Outdoor remote monitoring.
- Level / depth monitoring in tanks for liquids.
- Groundwater level monitoring.
- Level / depth monitoring in wells up to 300 meters deep.
- Water depth and temperature monitoring in running or open water.
- Relative pressure measurement.
- Absolute pressure measurement (on request).



decentLab

Decentlab GmbH

Ueberlandstrasse 129 – 8600 Duebendorf – Switzerland

Tel. +41 44 809 3595 – mail@decentlab.com – www.decentlab.com

Description

The device DL-PR36 enables remote monitoring of water level in open water, fill level of tanks, groundwater level and various other applications. It measures the pressure at the sensor head relative to the pressure at the cable end (device enclosure). When the sensor head is placed under water (or any other liquid), the relative pressure indicates the depth of the sensor head. In water, the relative pressure of 1 bar equals to a depth of approximately 10 m. Also available on request is a variant of the DL-PR36 which measures the absolute pressure at the sensor head, i.e., the pressure relative to zero bar (vacuum).

The device also reports the temperature of the sensor head with high precision. The temperature reading is also used internally for temperature compensation.

Sensor data are transmitted in real-time using LoRaWAN™ radio technology. LoRaWAN™ enables encrypted radio transmissions over long distances while consuming very little power. The user can obtain sensor data through Decentlab's data storage and visualization system, or through the user's own infrastructure. Visit <http://www.decentlab.com/> for more information about Decentlab's data cloud service.

Device variants

Name	Pressure range	Application
DL-PR36-001	0 to 1 bar (relative) other ranges: contact us	Water depth gauge (0 to 10 m), relative pressure

Device specifications

Device logging function

Sampling interval	10 min (configurable through the user interfaces)
Data upload interval	10 min (configurable through the user interfaces)
Transmitted sensor data	Pressure Temperature Device battery voltage (in mV)
SD-card logging	Optional

Pressure sensor specifications

Operating principle	Piezoresistive pressure measurement
Measurement range	0.0 to 1.0 bar (other ranges on request)
Resolution	0.000122 bar (= full scale / 8192)
Linearity / precision	max. ± 0.02 % of full scale
Total error band (max. deviation within 0...50 °C)	max. ± 0.1 % of full scale

Temperature sensor specifications

Resolution approximately	0.04 °C
Accuracy	typ. ± 0.3 °C (± 0.1 °C on request)

Radio / wireless

Wireless technology	LoRaWAN™
Wireless security	AES-128 data encryption
LoRaWAN device type	Class A end-device
Supported LoRaWAN features	OTAA, ABP, ADR, adaptive channel setup
Wireless range	> 10 km (line of sight), approx. 2 km (suburban) ¹
RF transmit power	14 dBm (25 mW)
Effective radiated power	11.9 dBm ²
Receiver sensitivity	-146 dBm ³
Frequency bands	868 MHz (EU version), 915 MHz (US version) ⁴
Antenna	Integrated omnidirectional antenna featuring a near-perfect radiation pattern ²

Device power supply

Internal battery type	2 × alkaline C batteries (R14)
Power consumption (average)	≤ 0.4 mW (10 min interval)
Battery lifetime estimation ⁵	> 3.6 years (10 min interval, SF7) > 2.4 years (10 min interval, SF12) > 10.4 years (60 min interval, SF7) > 8.3 years (60 min interval, SF12)

Operating conditions

Temperature	-20 to 50 °C
Humidity	0 to 100 % RH

1 Decentlab reports successful transmissions over 56 km distance

2 See Appendix A: Antenna performance measurement

3 Specified by radio chip vendor

4 Contact us for region specific options

5 Including alkaline battery self-discharge of 3.6 % per year (conservative estimation); battery capacity: 20000 mWh.

Mechanical specifications

Dimensions	135 × 81 × 70 mm (not including sensor / cable)
Weight	Device + batteries: 400 g; sensor head: 170 g (not including cable)
Enclosure	Polycarbonate; weatherproof, impact-, UV-resistant (IP66/IP67). Pressure equalizer plug with PTFE membrane (IP68).
Cable length	10 m (other cable lengths: contact us)
Sensor head	Length: 127 mm, diameter: 22 mm

Operating instructions

The product usually requires no user interaction. If you open the enclosure, e.g. in order to replace the batteries, unscrew the four plastic screws and carefully open the lid.

CAUTION: Make sure the sensor unit does not drop out of the enclosure while opening! Do not touch the electronic components and sensors!

NOTE: When closing the lid, make sure the lid is fitted the right way, so that the enclosure is properly sealed: A little nose in the enclosure fits a notch in the lid and vice versa.

Replacing batteries

Insert 2 high-quality alkaline C batteries (R14) into the battery holder on the back side of the sensor unit. The device operates until the battery voltage drops to 2.0 V. Always replace both battery cells with two identical fresh batteries.

User button and LEDs

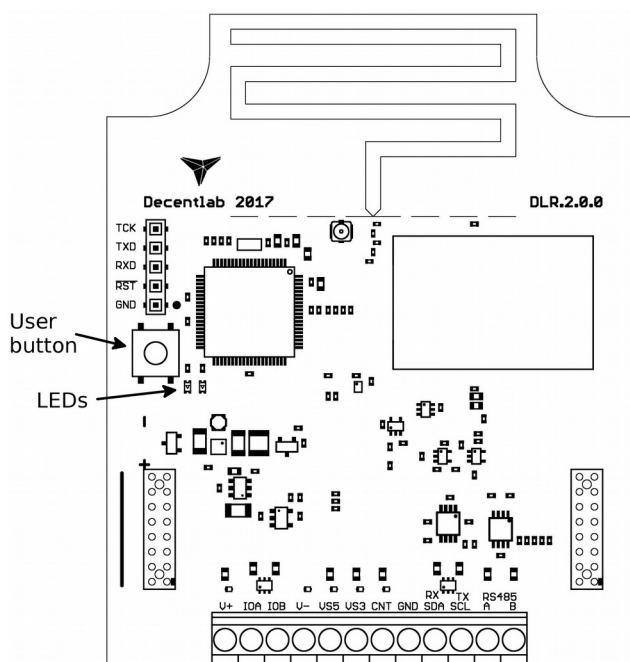

Illustration 1: Sensor unit (top side) showing the user button and the LEDs.

Operating modes

The device has three operating modes:

- **Reset:** System (re-)start; both LEDs light up for a short time.
- **Active mode:** Periodic measurements and data transmissions; green LED flashes for each measurement.
- **Test mode:** Measurements and data transmissions at fastest possible rates; blue LED is on. **NOTE:** Use only momentarily, e.g. for testing the wireless connection. The device will switch automatically to active mode after 20 min.
- **Sleep mode:** No measurements and data transmissions (power save mode, for shelf storage).

Switching between operating modes

The user button allows to switch between the operating modes as shown in Illustration 2. To perform a device reset, switch to sleep mode first (if necessary) by pushing the button for 3 seconds (until LEDs flash three times); wait 3 seconds; then push the button for 3 seconds (until LEDs light up). To switch between active and test mode, push the button for 1 second (blue LED on / off). If the blue LED is off, the device is in active or sleep mode. If the blue LED is on, the device is in test mode. To check whether the device is active or in sleep mode, push the button twice for 1 second; if the blue LED goes on and off, the device is in active mode; otherwise, the device is in sleep mode.

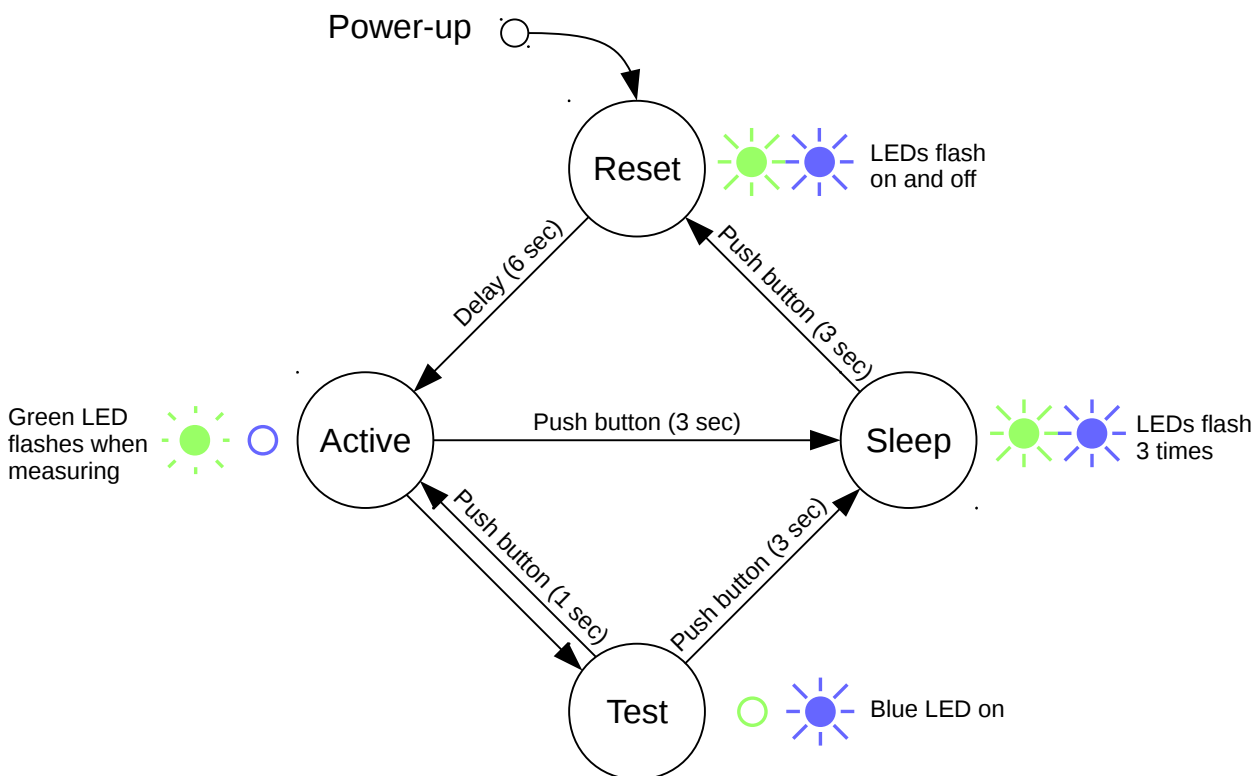

Illustration 2: Device operating mode state diagram.

Measurement cycle (active mode)

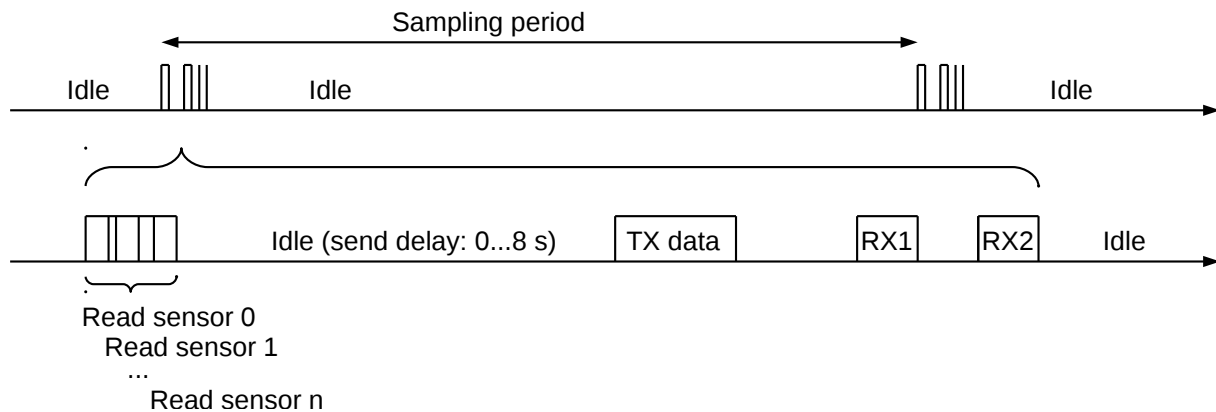

Illustration 3: Device activity during the active mode.

During the active mode, the device periodically reads the sensors (see Illustration 3). After a random delay of 0...8 seconds, the device transmits the sensor data. If the device has not yet joined the LoRaWAN network, it will try to join until it succeeds (maximum 3 attempts per sampling period). Afterwards, it will transmit the data (TX data). Following the data transmission, two receive slots are opened (RX1 and RX2). During these time slots, the device is ready to receive data from the network (downlink messages) as defined in the LoRaWAN™ specification.

As shown in Illustration 3, the device is idle most of the time. During the idle time, the current consumption is extremely low.

LED signaling (active mode)

- Read sensors: green LED flashes once.
- Data sent successfully: green LED flashes 2 times.
- Data could not be sent: green LED flashes 4 times.

Device configuration

The user can configure a rich set of device parameters, such as sampling interval, LoRaWAN data rate, ADR settings and many more. If desired, the parameter settings can be stored permanently in the internal non-volatile memory. The user can configure the device via two interfaces:

- Command line interface: via a serial cable (UART – USB) connected to a computer.
- Downlink command interface: over the air using LoRaWAN downlink messages.

For a full description of the command line interface and the downlink command interface, please find the specific documents on <https://www.decentlab.com/support>.

Mounting instructions

Prefer a mounting location which is protected against rain and direct sun radiation.

For best radio performance, position the device in such a way that the device lid faces roughly in the direction of the next gateway. Avoid metallic objects close to the device.

The housing includes 4 threaded bushes (M4) in a 90×60 mm rectangle (see Illustration 4). This enables easy installation using standard M4 bolts.

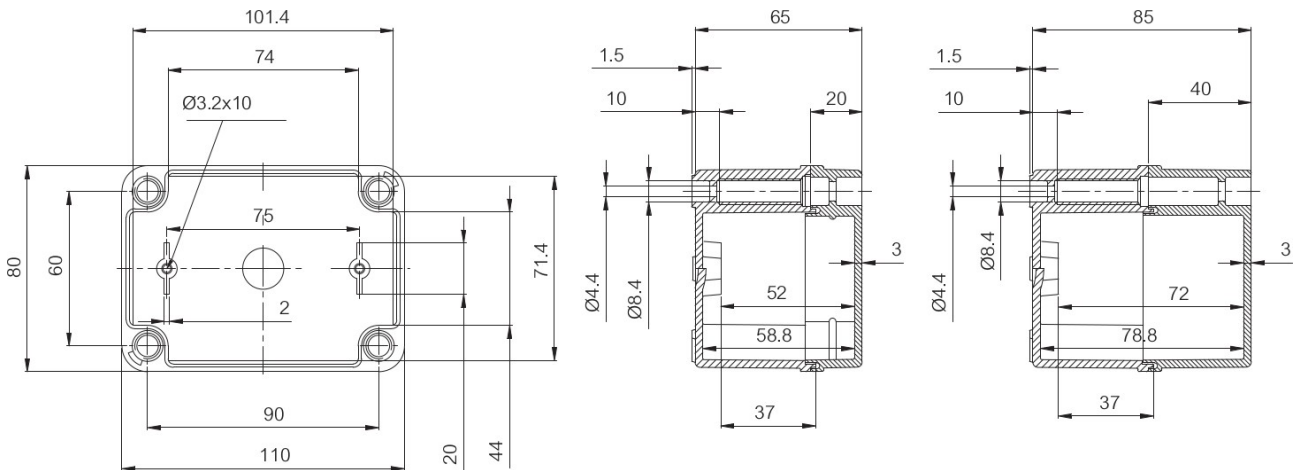

Illustration 4: Housing dimensions (in mm). Note: Drawing not including the cable gland.

Ordering information

Device model references

DL-PR36-001-EU868	0 to 1 bar, relative pressure, EU version
DL-PR36-001-US915	0 to 1 bar, relative pressure, US version
	Other options: contact us

Declaration of conformity

We,

Decentlab GmbH
Ueberlandstrasse 129
8600 Duebendorf
Switzerland,



declare under our own responsibility that the product

Reference	Name
DL-PR36-xxx-EU868	Decentlab LoRaWAN high-precision pressure / depth and temperature sensor

to which this declaration refers conforms with the relevant standards or other standards documents

- EN 300 220-1 V3.1.1: 2017-02
- EN 300 220-2 V3.1.1: 2017-02
- EN 301 489-1 V2.2.0: 2017-03
- EN 301 489-3 V2.1.1: 2017-03

According to

- Radio Equipment Directive (RED) 2014/53/EU
- Electromagnetic Compatibility (EMC) Directive 2014/30/EU

Duebendorf, 1. January 2019

Reinhard Bischoff, Managing Director

A handwritten signature in black ink, appearing to read 'R. Bischoff', written in a cursive style.

Sensor data message format

Message:	Header	Sensor 0 data (optional)	Sensor 1 data (opt.)	...	Sensor 15 data (opt.)
-----------------	--------	--------------------------	----------------------	-----	-----------------------

- Message length is variable, depending on which sensor data are included. Minimum length is 5 bytes (header only). Maximum length is 5 bytes + all sensor data (see below).
- Integers are big endian: MSB first byte, LSB last byte.

Header:	Version	Device ID	Flags
----------------	---------	-----------	-------

- Version: 1 byte; version = 2 for current protocol version.
- Device ID: 2 bytes; 0...65535.
- Flags: 16 bits: flag 15 | flag 14 | ... | flag 0 (LSB).
- The flags indicate, if data of the respective sensors are included in the message or not:
Flag n == 1: sensor n data included; flag n == 0: not included.

Details

Field	Parameter name	Type	Conversion	Unit
Header	Version	uint8		
Header	Device ID	uint16		
Header	Flags	uint16		
Sensor 0	Pressure	uint16	$(x - 32768) / k_p$	bar
Sensor 0	Temperature	uint16	$(x - 32768) / 256$	°C
Sensor 1	Battery voltage	uint16	$x / 1000$	V

Note: The value of k_p (pressure multiplier) has one of the following values:

- $k_p = 8192$ (for pressure range -4...4 bar);
- $k_p = 2048$ (for pressure range -16...16 bar).

Example 1 (all sensor data included)

Message (hex):

02032b0003806797810c2b (k_p = 8192)

02	Version	=	2	
032b	Device ID	=	811	
0003	Flags	=	0b0000000000000011	
8067	Pressure	=	0.0126	bar
9781	Temperature	=	23.50	deg
0c2b	Battery voltage	=	3.115	V

Example 2 (only battery voltage)

Message (hex):

02032b00020c2b

(kp = 8192)

02	Version	=		2
032b	Device ID	=		811
0002	Flags	=	0b00000000000000010	
----	Pressure	=		---- bar
----	Temperature	=		---- deg
0c2b	Battery voltage	=	3.115	V

Appendix A: Antenna performance measurement

No : DE.17.039.F01

Page 21 / 24

Measurement Results:

EUT	DLR1-LP8		
Test performed	Effective radiated power (ERP)		
Verdict, Test	Pass		
Modification	None		
Mode of operation	Transmitter mode		
Test date, time	13.06.2018 09:37:06		
Antenna height	1.30 m	Antenna polarization	Vertical
EUT position	0 to 360 Degree	Antenna distance	3 m
Measurement settings	Radimtion Version: 2017.1.6, RBW: 1 kHz, VBW: 300 kHz, Sweep time: Auto [120 ms], Step freq: Linear: 250 Hz steps, Attenuator: Auto [10 dB], Internal preamp: 20 dB, Measure time: 10 ms, Measurement equipment: TP_RE_30M-1G_ETSI_Ver		

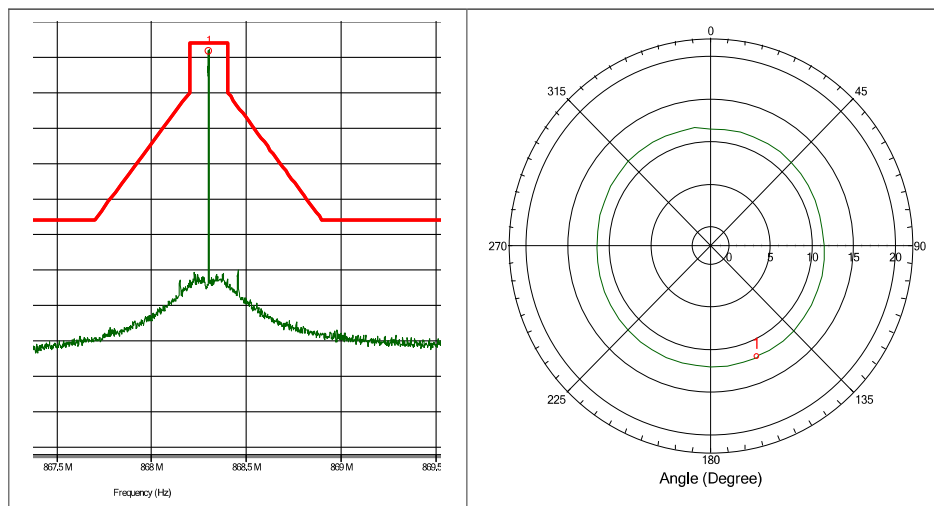

Detected peaks

Peak Number	Frequency	Peak	Peak Difference	Status	Angle	Height	Polarization
1	868.302 MHz	11.9 dBm	-2.14 dB	Pass	157 Degree	1.3 m	Vertical

Limits:

ETSI EN 300 220-2, Table C.1 OFB: 863 MHz to 870 MHz <= 0.1% duty cycle or polite spectrum access	25 mW e.r.p (14 dBm)
---	------------------------------------

EMV Prüfstelle Zürich – Technopark – 8005 Zürich